

E-Starter an einer Vespa nachrüsten

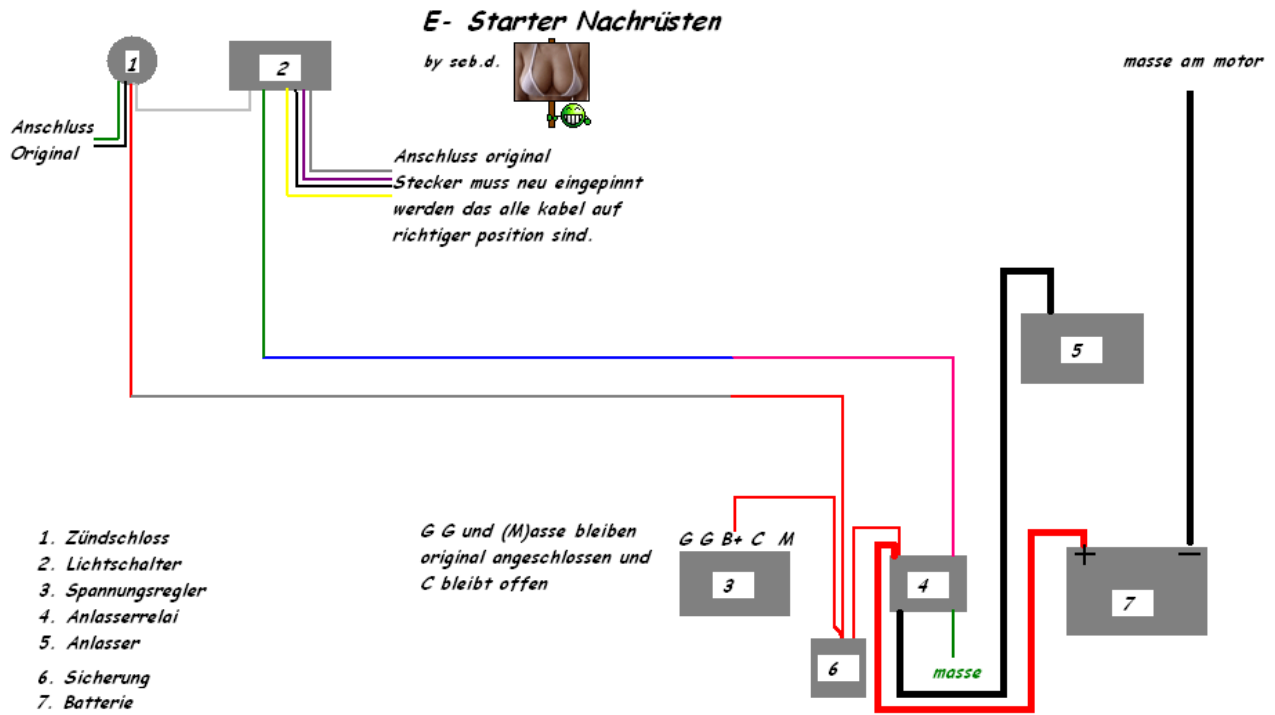



BATTERIE 12V/9AH, SIP,
für Vespa PX80-200 E Lusso-T5
/Cosa Elestart/PX125-200 E
`98/MY/`11 passt auch für
Vespa PK50-125 S/PK50 SS/XL/N
/Plurimatic/PK 125 ETS/N/XL
/XL2, für PIAGGIO 50-200ccm 2T
/4T AC/LC
135x75x140mm, Mikrovlies
Batterie, wartungsfrei,
versiegelt, vorgeladen, schw..

32,00 €
zzgl. 7,50 € Pfand

Art.Nr. **85046000**



STECKER ZÜNDSCHLOSS, FÜR VESPA
PK/S/SS/XL/Rush/N/PX Lusso
/T5
mit 4 Kabel (weiß/rot/grün
/schwarz) für E-Start

22,00 €

Art.Nr. **23102400**



SICHERUNGSKASTEN PIAGGIO FÜR
Vespa PX/ Lusso/T5 PKXL2/FL
/Autom./50HP elestart

5,60 €

Art.Nr. **29040200**



SPANNUNGSREGLER RMS FÜR VESPA
PK50 XL/N/Rush/PX125-200 E `98
/MY/`11/Cosa/T5,
12V 20A, 5 Anschlüsse, für
Batterie

36,00 €

Art.Nr. **85150000**



ANLASSER FÜR VESPA PK/S/ XL
/XL2/Automatica/APE 50 mit
Elestart

171,00 €

Art.Nr. **22519200**



KABELBAUM BATTERIE
/Sicherungskasten/Rahmen,
für Vespa PK50/XL/ Elestart/FL
/HP/N/Rush/XL2

23,80 €

Art.Nr. **23459500**



LICHTSCHALTER FÜR VESPA PK50
XL2 Elestart,
3 Kabel,
2 Multistecker (5/1 Pin)

59,00 €

Art.Nr. **29044400**



ANLASSER RELAIS PIAGGIO ELEK.,
..trostartert, für PIAGGIO
/Vespa Maxiscooter/PX/T5/PK,
12V, 4 Anschlüsse,

15,20 €

Art.Nr. **21882400**